



**PRECISION MOISTURE  
MEASUREMENT...**

**in seconds**

- Safe & easy-to-use
- Non-destructive
- For all paper types
- Moisture Range:  
1-15%
- Suitable for  
Incorporation into  
ISO Quality Systems

The Definitive At-Line Moisture  
Measurement Solution for  
Paper & Board Making,  
Converting and Printing Processes

---

# MOISTREX MX8000



---

**The Measure of Quality™**

# Moistrex MX8000

## For fast, accurate at-line moisture measurement...

Fast & easy to use, MX8000 is supplied pre-calibrated for instant results:

- 1 select the paper type
- 2 key in the grammage
- 3 insert the sample, and...
- 4 in just a few seconds the moisture value will be displayed on the easy-to-read LCD screen →

Plus...



For lighter papers  
MX8000-T80

The MX8000-T80 is optimized for moisture measurement of lighter paper basis weights from 30 to 400gsm.

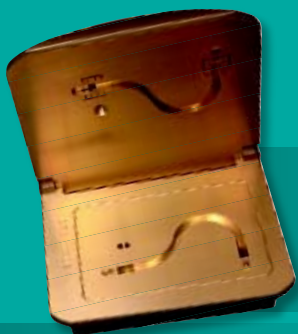

For heavier papers & boards  
MX8000-T20

The MX8000-T20 is optimized for the heavier 150 to 1200gsm range.



1



2



3



4

### MX8000 contains a waveguide...

down which a microwave signal is transmitted. When a paper sample is inserted, the waveguide is split in two by the paper and the water molecules within the paper attenuate the microwave signal, the attenuation being proportional to the amount of water in the paper; the detector then measures the "microwave loss" and converts this signal to a per cent moisture value.

MX8000 achieves reliable accurate measurements, even on heavier papers

By keying in the paper type and grammage, MX8000 automatically adjusts the settings to give reliable results time after time, without the need for special skills.

In addition to the factory pre-sets, the user can configure and store settings for up to 90 different paper types.

### Unaffected by colour, printing, surface finish or sizing...

Because the technique measures through the paper, the measurement is unaffected by colour or surface treatment, or stratification of moisture within the paper.

# Moistrex MX8000

## Delivering measurable value through...

### Time Savings

Compared to traditional loss-on-drying methods, MX8000 is many times faster and measures a much larger, more representative sample.

### Labour Savings

Using MX8000 to replace slow and labour intensive laboratory gravimetric testing means time and effort can be used more productively.

### Product Savings

Because MX8000 is fast, it can be used effectively to test product when process indicators suggest specifications are not being met.

### Testing Stock

MX8000 is also ideal for testing specifications of supplier stocks and in-coming paper products – before you process them.

## LIGHTWEIGHT CONSTRUCTION



- lightweight construction designed for maximum portability\*

\*carrying case optional

The solid alloy plates quickly stabilize the paper sample and an on-board sensor automatically compensates for temperature.

Since polythene and similar plastics do not cause microwave loss, paper samples can be stored in polythene bags and inserted, within the bag, into the MX8000. This means the integrity of samples is maintained and avoids the rapid changes which paper samples exhibit when stored unprotected, even for a short time.

## High stability for optimum performance...

MX8000 is designed to ensure its performance keeps pace with today's demand for precision at-line moisture measurement. With a "smart" detector module and high precision oscillator, MX8000 achieves reliable accurate measurements – even on heavier papers – with repeatability better than +/-0.1%.



## Quality and Conformance

MX8000 is manufactured by NDC within the framework of an ISO9001:2000 system. Each instrument is supplied with its Certificate of Conformance, and can be returned to NDC or tested by NDC's engineer on-site and the Certificate re-issued annually or as required. MX8000 can become part of an ISO Quality System for product traceability and process control.

## Flexible Connectivity

MX8000 has a plug-in Communications Module providing the following connectivity options:

- RS232
- USB
- Ethernet



Connected to a label printer, via RS232, MX8000 generates reports of the current measurements for hard copy filing. The USB port enables connection to a PC running NDC's GaugeToolsXL™ Data Management and Calibration Software. The Ethernet connection is used when data is required to be transmitted via a network for storage elsewhere or to a remote PC.

# Technical Specifications

## Moistrex MX8000

**Moisture Range:** 1 to 15% for most paper types

**Accuracy:** +/-0.1% moisture content

**Resolution:** better than 0.1% moisture content

**Operational Temperature:** 10° to 40°C

**Sample Size:** Minimum A4 [210 x 297mm] or US Letter [11 x 8.5 in]

**Display:** Back-lit LCD display. Tactile Keypad with 4 multi-function keys with intuitive operator interface software

**Language:** English plus all major world languages (user selectable)

**CE Compliance:** All NDC products are compliant with EN61010-1 Low Voltage Directive and EN 50082-2 EMC Directive

**Dimensions:** 270mm (W) x 328mm (D) x 108mm (H)

**Weight:** 7.2kg (excluding optional Carrying Case)

**Power Supply:** Universal input 100-240VAC, 50/60Hz

**R F Power:** Less than 2mW/cm<sup>2</sup>

**Sealing:** IP53 with lid closed

**Connectivity:** Optional Communications Module providing: RS232 to Printer, USB to PC, Ethernet to Network or PC

**Software:** GaugeToolsXL™ (NDC Proprietary) for Calibration & Data Management

**Options:** Carrying Case

## Paper Specifications

### Basis Weight:

MX8000-T80 for basis weights from 30 to 400gsm

MX8000-T20 for basis weights from 150 to 1200gsm

**Sample Thickness:** Up to 3mm

**Fibre Orientation:** MX8000 measures independently of fibre orientation

**Paper Type:** MX8000 is delivered with Product Stations pre-calibrated for most common paper & board types including:

#### MECHANICAL PULP:

Newsprint, Woodchip, Wallpaper

#### MIXED PULP:

Fiberboard, Coated Board, Cartridge

#### CHEMICAL PULP:

Brown Paper, Blotting, Writing, Bond, Quality Print

#### HIGHLY BEATEN:

Glassine Paper

#### COTTON LINTERS:

Banknote Paper

*There are 90 additional user-configurable Product Stations*

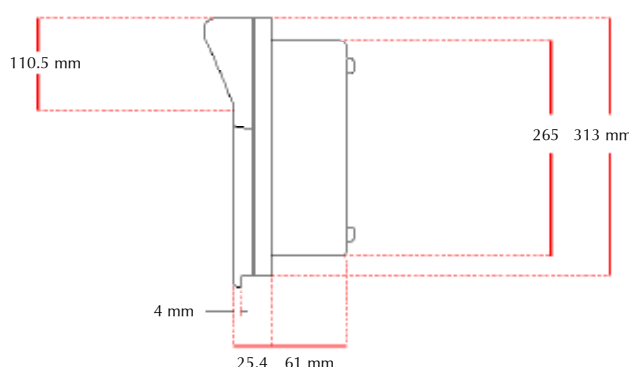
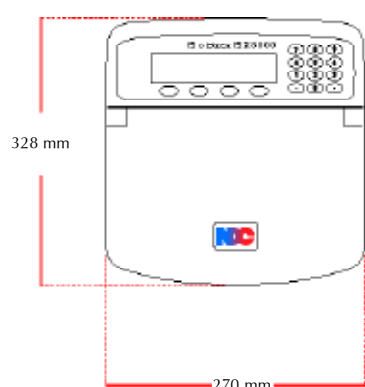

NDC Infrared Engineering is represented in over 60 countries worldwide

a **spectris** company

[www.ndcinfrared.com](http://www.ndcinfrared.com)

ISO9001:2000

#### NDC Infrared Engineering Ltd

Bates Road, Maldon  
Essex, CM9 5FA  
United Kingdom

Tel: +44 1621 852244

Fax: +44 1621 856180

Email: [sales@ndcinfrared.co.uk](mailto:sales@ndcinfrared.co.uk)

#### NDC Infrared Engineering Inc

5314 North Irwindale Avenue  
Irwindale, CA 91706  
United States of America

Tel: +1 626 960 3300

Fax: +1 626 939 3870

Email: [info@ndcinfrared.com](mailto:info@ndcinfrared.com)

#### NDC China

Tel: +86 20 8666 2790

Email: [info@ndcinfrared.com.cn](mailto:info@ndcinfrared.com.cn)

#### NDC Germany

Tel: +49 1801 977112

Email: [info@ndcinfrared.de](mailto:info@ndcinfrared.de)

#### NDC Italy

Tel: +39 (0331) 454 207

Email: [info@ndcinfrared.it](mailto:info@ndcinfrared.it)

#### NDC France

Tel: N° Azur: 0810 600 400

Email: [info@ndcinfrared.fr](mailto:info@ndcinfrared.fr)

#### NDC Japan

Tel: +81 3 3255 8157

Email: [info@ndcinfrared.jp](mailto:info@ndcinfrared.jp)

#### NDC Brazil

Tel: +55 11 5188 8172 / 8175

Email: [info@ndcinfrared.com.br](mailto:info@ndcinfrared.com.br)